

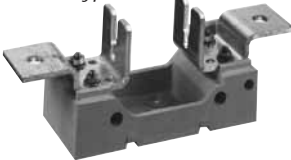

Update: 08.2018

Semiconductor Fuses AC+DC Square-boby Fuse Bases Bases for PSC ranges: SI TT, SI 000/00, SI DIN

SI TT
for stud-type fuses



SI 00
for bracket-type fuses



SI 000
for bracket-type fuses

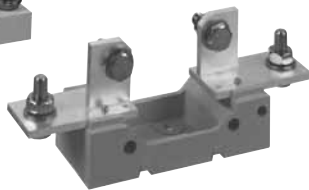

SI DIN 80 and 110
for blade-type fuses

STANDARD VERSION SI FUSEHOLDERS FOR STUD-TYPE FUSES, FOR BLADE-TYPE FUSES SI 00 AND SI 000, FOR BRACKET-TYPE FUSES SI DIN 80 AND DIN 110

- MOUNTING IN ONE-POLE FUSEHOLDER SIMPLIFIES FUSE REPLACEMENT FOR INSTALLATIONS CONNECTED WITH CABLES AND BARS
- FOR TTF STUD-TYPE FUSES
FOR BLADE AND BRACKET-TYPE FUSES AS PER DIN 43653 STANDARD
SIZES: 000 - 00, 80 MM BETWEEN AXES
SIZES: 0 - 1 - 2 - 3, 80 AND 110 MM BETWEEN AXES
- FOR TTF VERSION STUDS ARE DELIVERED WITH THE FUSE HOLDER
- FINGER SAFE VERSION AVAILABLE

Main characteristics

Designation	Insulation voltage Ui (AC 50/60 Hz & DC) (V)	Rating Current (A)	Maximum power* (W)	Dielectric withstand test		Fire and fumes class
				RMS voltage 1 mn 50/60 Hz (kV)	Impulse voltage 1.2/50ms (kV)	
SI TT 30/31	1500 V	1000	53 - 75	10	12	UL 94 VO
SI TT 70/71	1500 V	1000	53 - 75	10	12	
SI TT 32/33	1500 V	2500	100	10	12	
SI TT 72/73	1500 V	2500	100	10	12	
SI 000 DIN 80	700 V	400	24	7	8	UL 94 VO
SI 00 DIN 80	700 V	400	28	8	12	UL 94 VO
SI DIN 80 630 (30 to 33)	1500 V	2500	95	10	12	UL 94 VO
SI DIN 110 630 (30 to 33 - 70 to 73)	1500 V	2500	95	10	12	
SI DIN 80 1250 (30 to 33)	1500 V	2500	110	10	12	
SI DIN 110 1250 (30 to 33 - 70 to 73)	1500 V	2500	110	10	12	

Vibration withstand for standard version:

Tests with sine vibrations carried out at ambient with scanning each of the three main axes of the holder.

Spectrum: 1st segment (2 to 16 Hz) constant displacement x = 5 mm peak.

2nd segment (16 to 250 Hz) constant acceleration = 5 g peak.

Exponential scanning speed: 1 octave per minute.

Duration: 2 hours per axis.



Semiconductor Fuses

AC+DC Square-boby Fuse Bases

Bases for PSC ranges: SI TT, SI 000/00, SI DIN

STANDARD VERSION SI FUSEHOLDERS

Reference and catalog numbers

Designation	Ref. Number	Weight (g)	Packaging	Catalog Number
SI TT 30/31	B 301232	1 960	1	SITT30/31
SI TT 70/71	C 301233	1 960	1	SITT70/71
SI TT 32/33	D 301234	2 900	1	SITT32/33
SI TT 72/73	E 301235	2 900	1	SITT72/73
SI 000 DIN 80	C 220710	90	12	SI000DN80
SI 00 DIN 80	Q 098040	205	3	SI00DN80
C - CLO*	M 091344	37	2	CLO
SI DIN 80 630	L 098772	625	1	SIDN80630A
SI DIN 110 630	F 098031	625	1	SIDN110630A
SI DIN 80 1250	F 098560	885	1	SIDN801250A
SI DIN 110 1250	L 091941	885	1	SIDN1101250A

* Necessary for SI 00 DIN 80 one-pole mounting.

Distance "X" Between Poles Axes (Without Partition)

Designation	Fuses sizes	Operating voltage U				
		400V	550V	690V	1000 V	1250 V
SI TT 30/31	30 - 31	58,5	61	65	71	76
SI TT 70/71	70 - 71					
SI TT 32/33	32 - 33	79,5	84,5	88,5	94,5	99,5
SI TT 72/73	72 - 73					
SI 000 DIN 80	000	25	35	39	45	50
SI 00 DIN 80	00	46,5	46,5	46,5	50	55
SI DIN 80	30 - 31	58,5	61	65	71	76
630/1250	32 - 33	79,5	84,5	88,5	94,5	99,5
SI DIN 110	30 - 31 - 70 - 71	58,5	61	65	71	76
630/1250	32 - 33 72 - 73	79,5	84,5	88,5	94,5	99,5

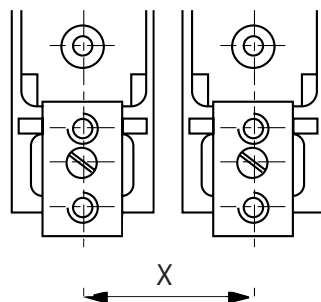



Semiconductor Fuses AC+DC Square-boby Fuse Bases Bases for PSC ranges: SI TT, SI 000/00, SI DIN

STANDARD VERSION SI FUSEHOLDERS

Connection dimensions

SI TT

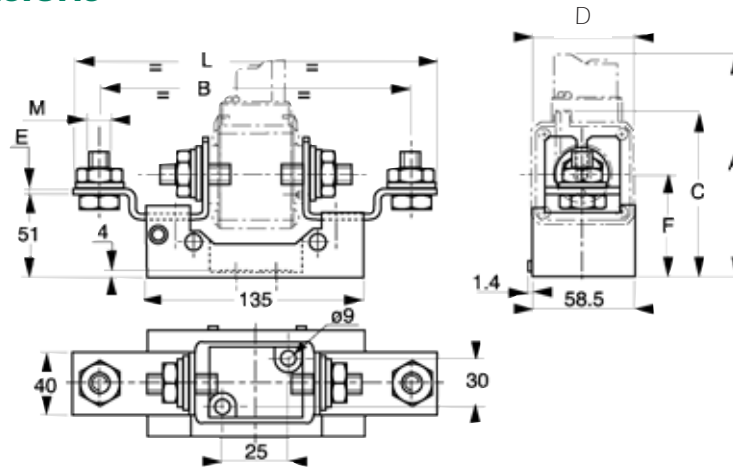

Designation	A	B	C	D	E	G	L	M	F	Catalog Number
SI TT 30/31	118(30) 123(31)	170	83 (30) 88 (31)	42(30) 51(31)	4	50,6	202	M8	57	
SI TT 70/71	118(70) 123(71)	193	83 (70) 88 (71)	42(70) 51(71)	4	74	225	M8	67	
SI TT 32/33	137(32) 145(33)	170	93 (32) 109 (33)	60(32) 75(33)	6	50,6	202	M10 (32) M12 (33)	57	
SI TT 72/73	137(72) 145(73)	193	93 (72) 109 (73)	60(72) 75(73)	6	71	225	M10 (32) M12 (33)	67	

Partition mounting not possible. Panel drilling: 25x30 mm

SI 00 DIN 80

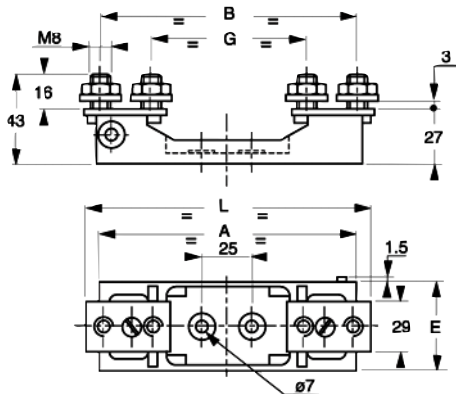

SI 000 DIN 80

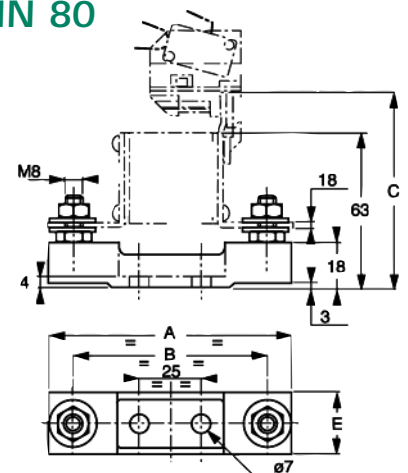

Designation	A	B	C	D	E	G	L	Fuse sizes	Catalog Number
SI 000 DIN 80	100	80	80	19	25	80	100	000-17x49-27x60 DIN 80	
SI 00 DIN 80	133	130			46.5	79	148	00-27x60 DIN 80	

Partition mounting only for SI 00 DIN 80

* Electrical connection of fuse and fuse holder via supplied studs, nuts and washers

Maximum recommended tightening torque: M8 screws 13.5 Nm (SI...TT... and SI 00) or 9 Nm (SI 000)
M10 screws 26 Nm (SI...TT... and SI 00)
M12 screws 46 Nm (SI...TT... and SI 00)

M6 for SI 000 and SI 00 Tightening torque 7 ± 15 Nm.
M8 for SI TT Tightening torque 10 ± 2 Nm.

Fixing of base on plate or bar via screws not supplied.



Semiconductor Fuses

AC+DC Square-boby Fuse Bases

Bases for PSC ranges: SI TT, SI 000/00, SI DIN

STANDARD VERSION SI FUSEHOLDERS

SI DIN 80-110

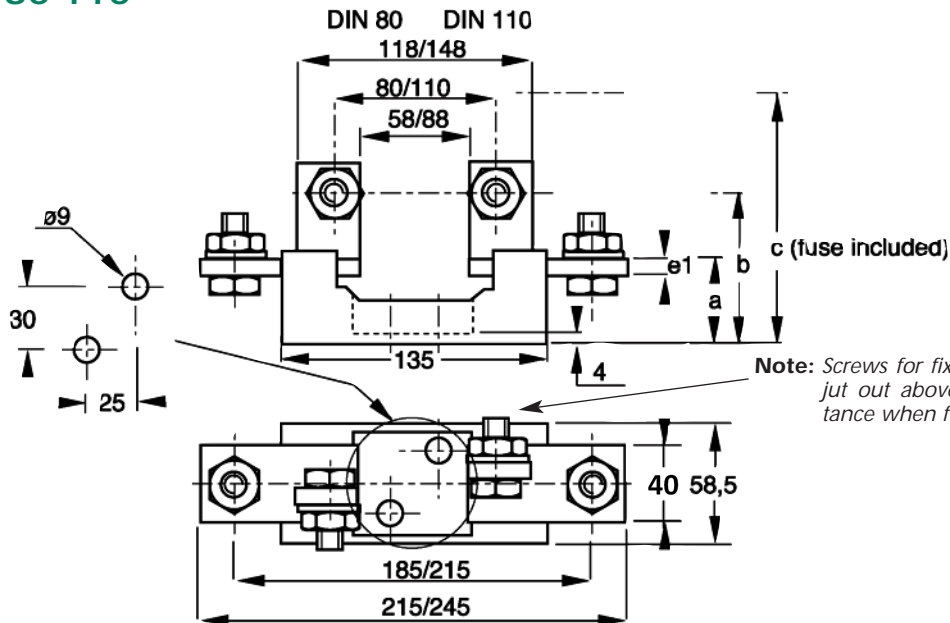

Designation	a	e1	b	c	Fuse Size	Catalog Number
SI DIN 80 630	40	5	68	93.5	30 D08	
				99.0	31 D08	
				103.5	32 D08	
				110.3	33 D08	
SI DIN 110 630	40	5	68	93.5	30-70 D11	
				99.0	31-71 D11	
				103.5	32-72 D11	
				110.3	33-73 D11	
SI DIN 80 1 250	45	10	73	98.5	30 D08	
				104	31 D08	
				108.5	32 D08	
				115.3	33 D08	
SI DIN 110 1 250	45	10	73	98.5	30-70 D11	
				104	31-71 D11	
				108.5	32-72 D11	
				115.3	33-73 D11	

Partition mounting impossible

* Electrical connection of fuse and wires by M10x30 screws made in plated steel minimum 8-8 class.
Screws included.

Maximum recommended tightening torque: $44 \pm \frac{0}{8}$ Nm for M10 screw.

- Fixing of base with screws not supplied: M8. Tightening torque 10 ± 2 Nm.